

Performance.. at it's Peak !

Magnetic Pump

12 LPM

Very compact, Sleek, Splash proof design
Suitable to almost all chemicals
Sealless pump means no contamination
PP chamber makes it corrosion resistant
High efficiency, High performance, Low heating
Centrifugal, non self priming Pump.



Applications

Chemical, Pharmaceutical & Textile Industries,
Electroplating equipment, Medical equipment,
Galvanizing facilities, pure water plants,
Water treatment plants, Ice makers, Soft drink
dispensers, Boilers, Heat exchangers, Solar systems,
Dye bath, Wafer processors, Color-Black & White
film processors, X - ray film processors, Metal
recovery systems, Refridgeration & Chilling Units,
ED Machines, etc.

Specifications

Supply Voltage : 230 / 110 V 50/60 Hz 1 Ph,
: 230 / 440 V 50/60 Hz 3Ph

Power Input : 15 Watt

Max. Discharge : 12 Liter / Min.

Max. Head : 1.8 Meter

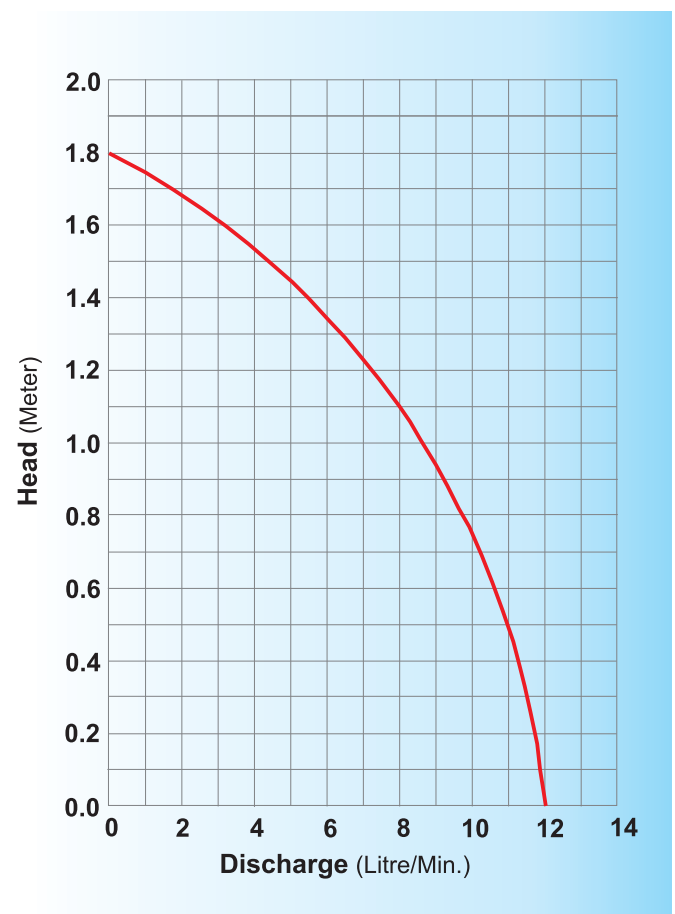

Magnetic Pump 12 LPM

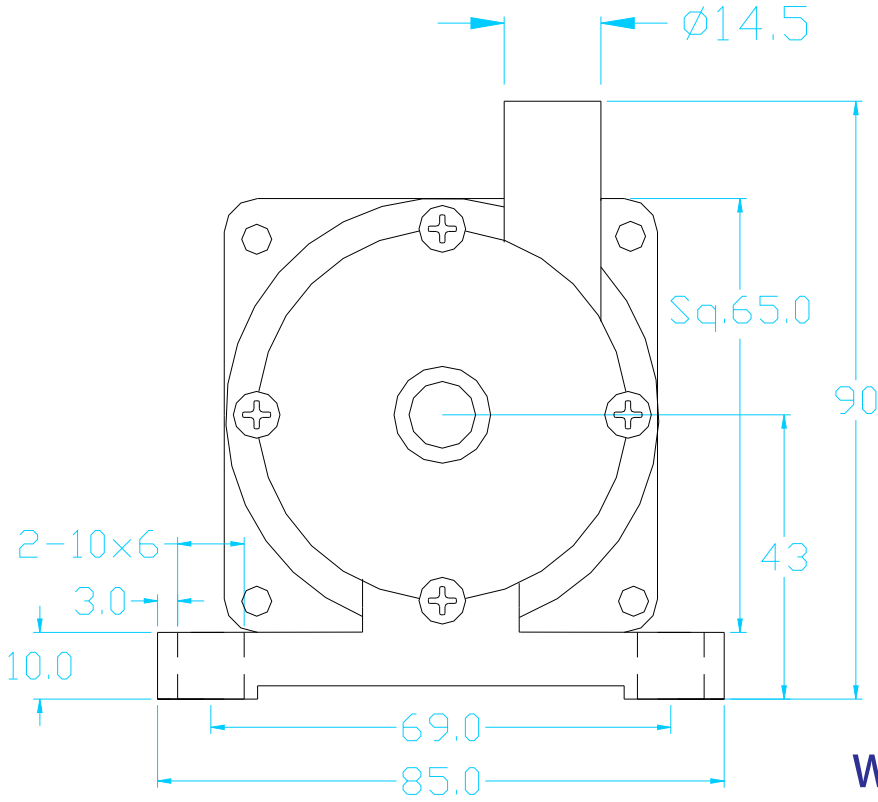
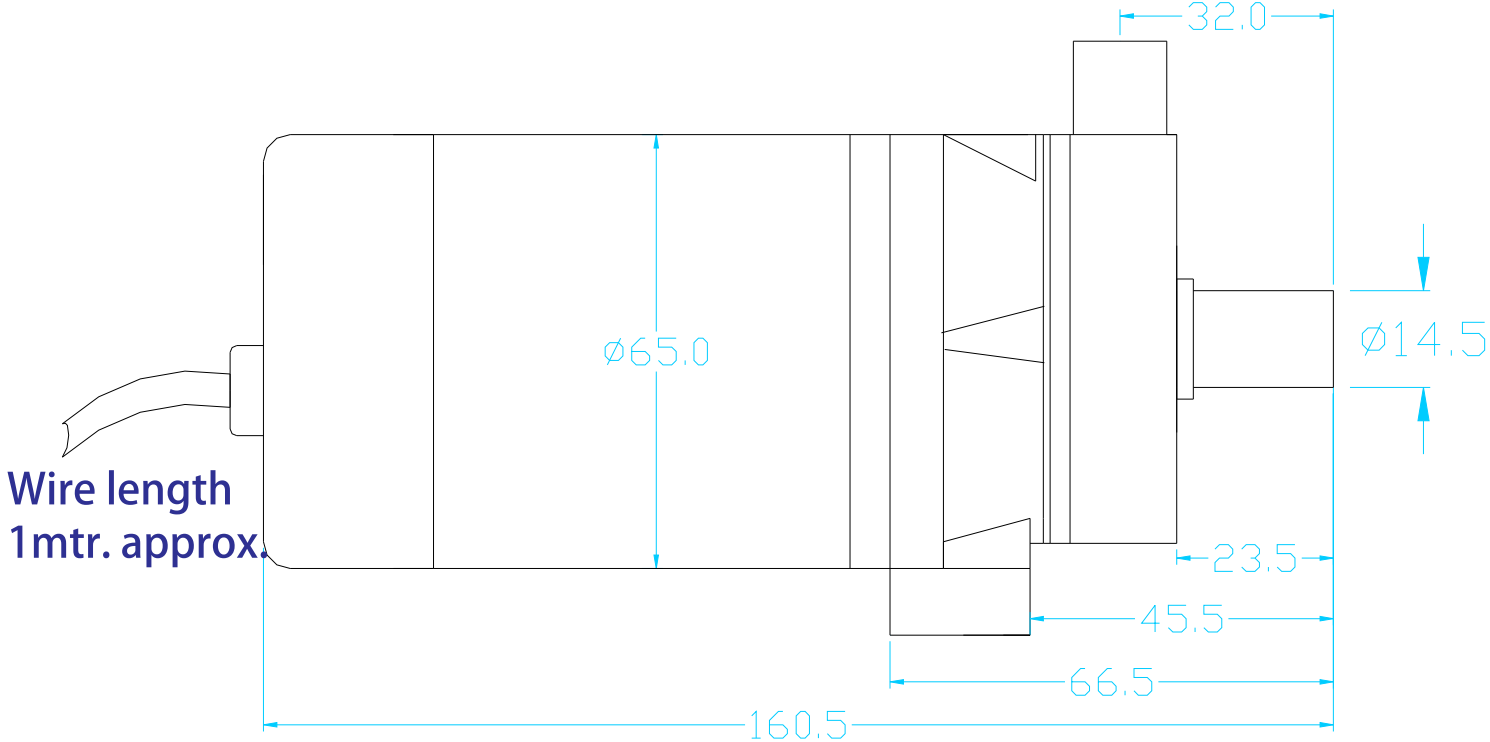

Weight : 1.2 Kg